



# INSTALLATION INSTRUCTIONS

PART NUMBER: 54-6853

This Assembly Fits:  
UNIVERSAL APPLICATION

SEE KNFILTERS.COM FOR CARB STATUS ON EACH PART FOR A SPECIFIC VEHICLE

Congratulations, you have purchased the finest custom air cleaner that money can buy. With proper care, this filter will last 1 million miles or more. This custom air cleaner replaces the stock air cleaner assembly. The following procedure **MUST** be followed to ensure a proper fit and seal of the custom air cleaner.

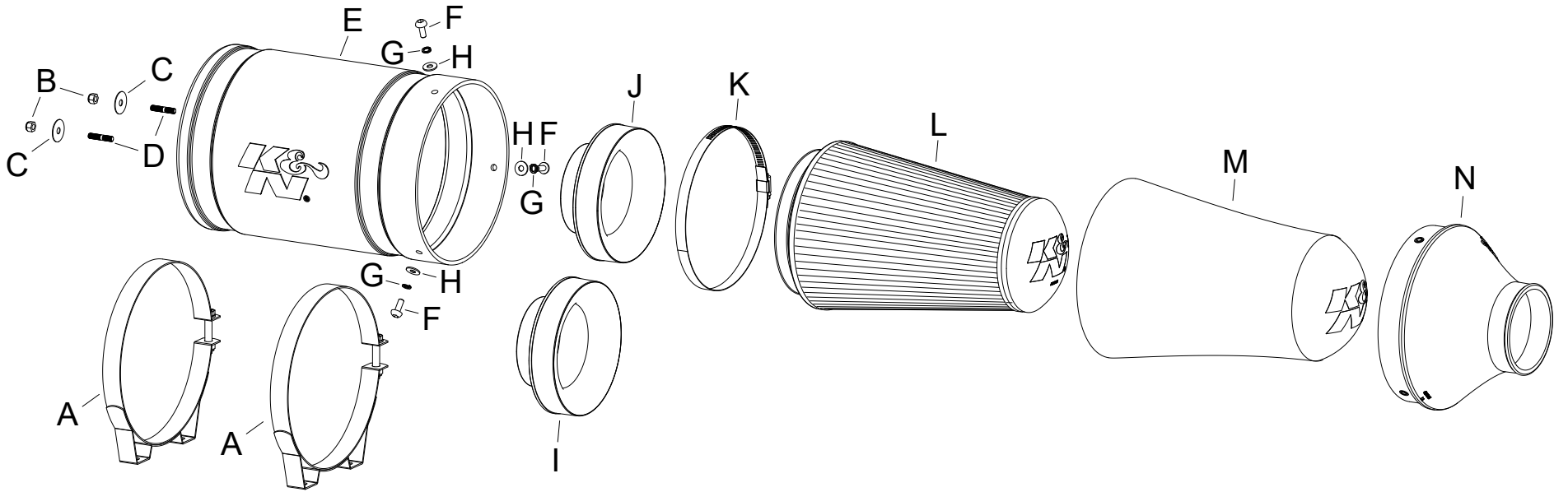

## PARTS LIST:

Description	Qty.	Part #	Description	Qty.	Part #	Description	Qty.	Part #
A SADDLE CLAMP; 8" DUAL	2	07293	F BOLT; M6 X 1.00 X 16MM, SS	3	07730	K HOSE CLAMP #104	1	08697
B NUT; 6MM NYLOCK, HEXHEAD	2	07512	G WASHER, M6 SPLIT LOCK ZINC	3	1-3025	L 6" FLG; 7-1/2"B X 5-1/8"T	1	RU-5064
C WASHER; 1"D X 1/4 HOLE	2	08160	H WASHER; 6MM FLAT, SS	3	08269	M FOAM FILTER WRAP	1	25-5167
D STUD, 6M-1 X 30 DBL ENDED	2	1-107	I ADAPTER; UNIVERSAL, 6" 3.5	1	21512-1	N LID; UNIVERSAL, LA, XLHDPE	1	087326A
E CANNISTER, 63-1133, LC	1	087328A	J ADAPTOR; 57-3058 #454	1	27300			

If you need any assistance please call 1-800-858-3333 to speak with a representative in our Customer Service Center before returning the product.

**NOTE: FAILURE TO FOLLOW INSTALLATION INSTRUCTIONS AND NOT USING THE PROVIDED HARDWARE MAY DAMAGE THE INTAKE TUBE, THROTTLE BODY AND ENGINE.**

## TO START:



1. Install the Extreme Duty Foam Wrap onto the filter.



2. Install the radius filter adapter into the air filter and secure with the provided hose clamp.



3. Install the two provided 6mm studs into the radius filter adapter as shown.

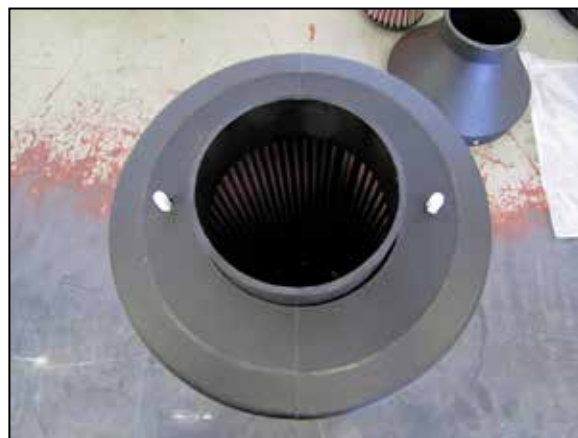

4. Install the filter assembly into the canister so that the studs protrude out of the holes.



5. Secure the filter assembly to the canister with the provided fender washers and nuts.



6. Install the canister lid onto the canister and secure with the provided hardware.



7. Install the saddle clamps onto the canister and secure with the provided hardware.



8. Your UNIVERSAL OFF ROAD AIR FILTER is ready to be installed.

#### ROAD TESTING:

1. Start the engine with the transmission in neutral. Listen for air leaks or odd noises. For air leaks secure hoses and connections. For odd noises, find cause and repair before proceeding.

2. Test drive the vehicle. Listen for odd noises or rattles and fix as necessary.

3. It will be necessary for all K&N® high flow intake systems to be checked periodically for realignment, clearance and tightening of all connections. Failure to follow the above instructions or proper maintenance may void warranty.

4. K&N Engineering, Inc., requires cleaning the intake system's air filter element every 50,000 miles. When used in dusty or off-road environments, our filters will require cleaning more often. We recommend that you visually inspect your filter once every 25,000 miles to determine if the screen is still visible. When the screen is no longer visible some place on the filter element, it is time to clean it. To clean and re-oil, purchase our filter Recharger® service kit, part number 99-5050 or 99-5000 and follow the easy instructions.

**LEGAL IN CALIFORNIA ONLY FOR RACING VEHICLES  
WHICH MAY NEVER BE USED, REGISTERED  
OR LICENSED FOR USE UPON A HIGHWAY.**

See [knfilters.com](http://knfilters.com) for CARB status on each part for a specific vehicle